

Features

- 10 ns pin-to-pin logic delays on all pins
- f_{CNT} to 111 MHz
- 288 macrocells with 6,400 usable gates
- Up to 292 user I/O pins
- 5 V in-system programmable
 - Endurance of 10,000 program/erase cycles
 - Program/erase over full voltage and temperature range
- Enhanced pin-locking architecture
- Flexible 36V18 Function Block
 - 90 product terms drive any or all of 18 macrocells within Function Block
 - Global and product term clocks, output enables, set and reset signals
- Extensive IEEE Std 1149.1 boundary-scan (JTAG) support
- Programmable power reduction mode in each macrocell
- Slew rate control on individual outputs
- User programmable ground pin capability
- Extended pattern security features for design protection
- High-drive 24 mA outputs with 3.3 V or 5 V I/O capability
- PCI compliant (-10 speed grade)
- Advanced 0.6 μ m CMOS 5V FastFLASH technology
- Available in a 208-pin and 304-pin HQFP packages

Description

The XC95288 is a high-performance CPLD providing advanced in-system programming and test capabilities for general purpose logic integration. It is comprised of sixteen 36V18 Function Blocks, providing 6,400 usable gates with propagation delays of 10 ns. See Figure 1 for the architecture overview.

Power Management

Power dissipation can be reduced in the XC95288 by configuring macrocells to standard or low-power modes of operation. Unused macrocells are turned off to minimize power dissipation.

Operating current for each design can be approximated for specific operating conditions using the following equation:

$$I_{CC} \text{ (mA)} = MC_{HP} (1.7) + MC_{LP} (0.9) + MC (0.006 \text{ mA/MHz}) f$$

Where:

MC_{HP} = Macrocells in high-performance mode

MC_{LP} = Macrocells in low-power mode

MC = Total number of macrocells used

f = Clock frequency (MHz)

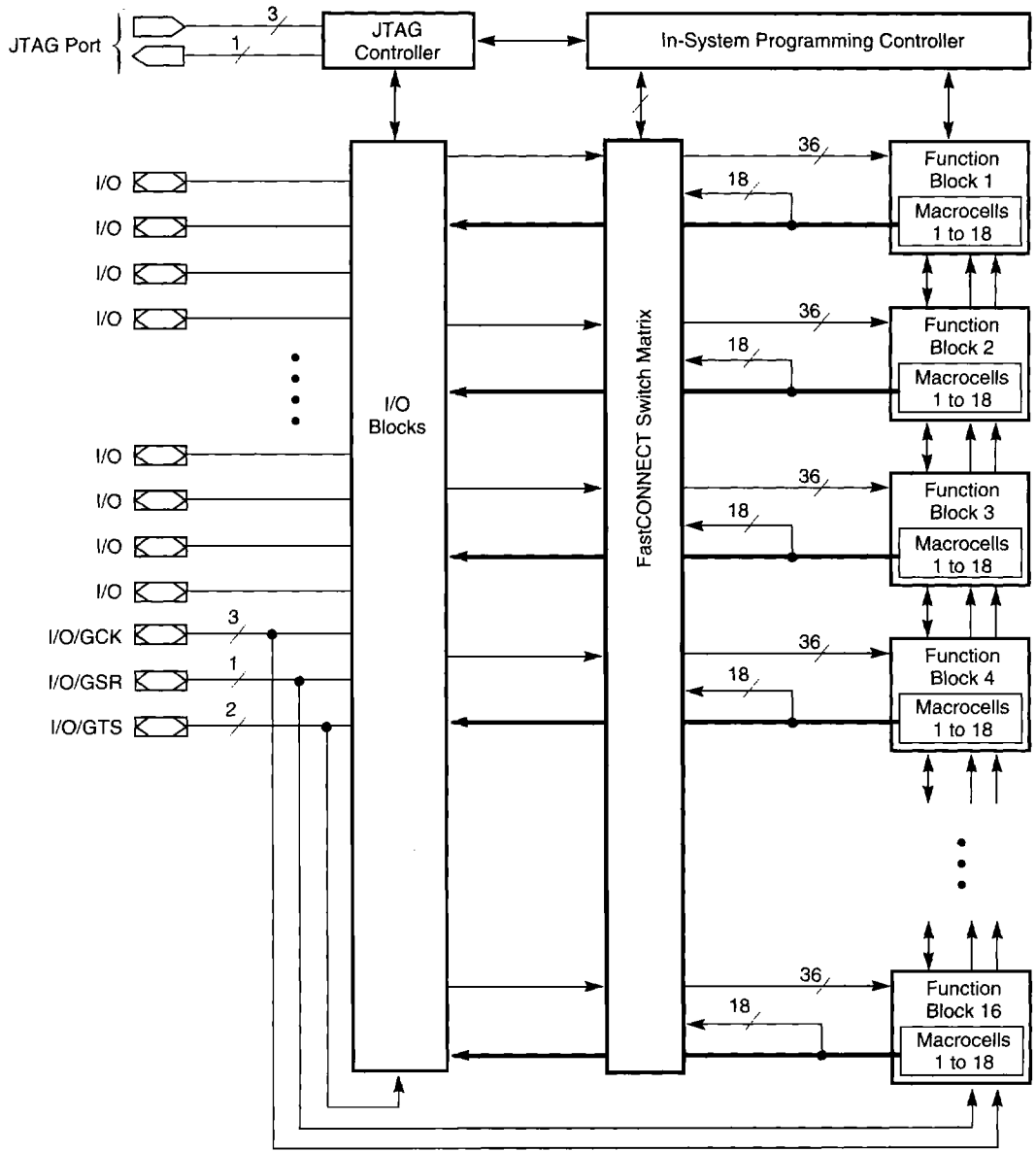

X5924

Figure 1: XC95288 Architecture

Note: Function Block outputs indicated by bold line drive directly to I/O Blocks

XC95288 I/O Pins

Function Block	Macrocell	HQ208	BScan Order	Notes
1	1	-	861	
1	2	28	858	
1	3	29	855	
1	4	-	852	
1	5	30	849	
1	6	31	846	
1	7	-	843	
1	8	32	840	
1	9	-	837	
1	10	33	834	
1	11	-	831	
1	12	34	828	
1	13	-	825	
1	14	35	822	
1	15	36	819	
1	16	-	816	
1	17	37	813	
1	18	-	810	
2	1	-	807	
2	2	15	804	
2	3	16	801	
2	4	-	798	
2	5	17	795	
2	6	18	792	
2	7	-	789	
2	8	19	786	
2	9	-	783	
2	10	20	780	
2	11	-	777	
2	12	21	774	
2	13	-	771	
2	14	22	768	
2	15	23	765	
2	16	-	762	
2	17	25	759	
2	18	-	756	

Function Block	Macrocell	HQ208	BScan Order	Notes
3	1	-	753	
3	2	38	750	
3	3	39	747	
3	4	-	744	
3	5	40	741	
3	6	41	738	
3	7	-	735	
3	8	43	732	
3	9	-	729	
3	10	44	726	[1]
3	11	-	723	
3	12	45	720	
3	13	-	717	
3	14	46	714	[1]
3	15	47	711	
3	16	-	708	
3	17	48	705	
3	18	-	702	
4	1	-	699	
4	2	3	696	[1]
4	3	4	693	
4	4	-	690	
4	5	5	687	[1]
4	6	6	684	
4	7	-	681	
4	8	7	678	[1]
4	9	-	675	
4	10	8	672	
4	11	-	669	
4	12	9	666	[1]
4	13	-	663	
4	14	10	660	
4	15	12	657	
4	16	-	654	
4	17	14	651	
4	18	-	648	

Notes: [1] Global control pin

Macrocell outputs to package pins subject to change, contact factory for latest information. Power, GND, JTAG and Global Signals are fixed.

Consult factory for HQ304 pinouts.

XC95288 I/O Pins (continued)

Function Block	Macrocell	HQ208	BScan Order	Notes
5	1	–	645	
5	2	49	642	
5	3	50	639	
5	4	–	636	
5	5	51	633	
5	6	54	630	
5	7	–	627	
5	8	55	624	[1]
5	9	–	621	
5	10	56	618	
5	11	–	615	
5	12	57	612	
5	13	–	609	
5	14	58	606	
5	15	60	603	
5	16	–	600	
5	17	61	597	
5	18	–	594	
6	1	–	591	
6	2	197	588	
6	3	198	585	
6	4	–	582	
6	5	199	579	
6	6	200	576	
6	7	–	573	
6	8	201	570	
6	9	–	567	
6	10	202	564	
6	11	–	561	
6	12	203	558	
6	13	–	555	
6	14	205	552	
6	15	206	549	[1]
6	16	–	546	
6	17	208	543	
6	18	–	540	

Function Block	Macrocell	HQ208	BScan Order	Notes
7	1	–	537	
7	2	62	534	
7	3	63	531	
7	4	–	528	
7	5	64	525	
7	6	66	522	
7	7	–	519	
7	8	67	516	
7	9	–	513	
7	10	69	510	
7	11	–	507	
7	12	70	504	
7	13	–	501	
7	14	71	498	
7	15	72	495	
7	16	–	492	
7	17	73	489	
7	18	–	486	
8	1	–	483	
8	2	186	480	
8	3	187	477	
8	4	–	474	
8	5	188	471	
8	6	189	468	
8	7	–	465	
8	8	191	462	
8	9	–	459	
8	10	192	456	
8	11	–	453	
8	12	193	450	
8	13	–	447	
8	14	194	444	
8	15	195	441	
8	16	–	438	
8	17	196	435	
8	18	–	432	

Note: [1] Global control pin

XC95288 I/O Pins (continued)

Function Block	Macrocell	HQ208	BScan Order	Notes
9	1	-	429	
9	2	74	426	
9	3	75	423	
9	4	-	420	
9	5	76	417	
9	6	77	414	
9	7	-	411	
9	8	78	408	
9	9	-	405	
9	10	80	402	
9	11	82	399	
9	12	83	396	
9	13	-	393	
9	14	84	390	
9	15	85	387	
9	16	-	384	
9	17	86	381	
9	18	-	378	
10	1	-	375	
10	2	170	372	
10	3	171	369	
10	4	-	366	
10	5	173	363	
10	6	174	360	
10	7	-	357	
10	8	175	354	
10	9	-	351	
10	10	178	348	
10	11	179	345	
10	12	180	342	
10	13	-	339	
10	14	182	336	
10	15	183	333	
10	16	-	330	
10	17	185	327	
10	18	-	324	

Function Block	Macrocell	HQ208	BScan Order	Notes
11	1	-	321	
11	2	87	318	
11	3	88	315	
11	4	-	312	
11	5	89	309	
11	6	90	306	
11	7	-	303	
11	8	91	300	
11	9	-	297	
11	10	95	294	
11	11	97	291	
11	12	99	288	
11	13	-	285	
11	14	100	282	
11	15	101	279	
11	16	-	276	
11	17	102	273	
11	18	-	270	
12	1	-	267	
12	2	158	264	
12	3	159	261	
12	4	-	258	
12	5	160	255	
12	6	161	252	
12	7	-	249	
12	8	162	246	
12	9	-	243	
12	10	164	240	
12	11	165	237	
12	12	166	234	
12	13	-	231	
12	14	167	228	
12	15	168	225	
12	16	-	222	
12	17	169	219	
12	18	-	216	

XC95288 I/O Pins (continued)

Function Block	Macrocell	HQ208	BScan Order	Notes
13	1	–	213	
13	2	103	210	
13	3	106	207	
13	4	–	204	
13	5	107	201	
13	6	109	198	
13	7	–	195	
13	8	110	192	
13	9	–	189	
13	10	111	186	
13	11	112	183	
13	12	113	180	
13	13	–	177	
13	14	114	174	
13	15	115	171	
13	16	–	168	
13	17	116	165	
13	18	–	162	
14	1	–	159	
14	2	144	156	
14	3	145	153	
14	4	–	150	
14	5	146	147	
14	6	147	144	
14	7	–	141	
14	8	148	138	
14	9	–	135	
14	10	149	132	
14	11	150	129	
14	12	151	126	
14	13	–	123	
14	14	152	120	
14	15	154	117	
14	16	–	114	
14	17	155	111	
14	18	–	108	

Function Block	Macrocell	HQ208	BScan Order	Notes
15	1	–	105	
15	2	117	102	
15	3	118	99	
15	4	–	96	
15	5	119	93	
15	6	120	90	
15	7	–	87	
15	8	121	84	
15	9	–	81	
15	10	122	78	
15	11	123	75	
15	12	125	72	
15	13	–	69	
15	14	126	66	
15	15	127	63	
15	16	–	60	
15	17	128	57	
15	18	–	54	
16	1	–	51	
16	2	131	48	
16	3	133	45	
16	4	–	42	
16	5	134	39	
16	6	135	36	
16	7	–	33	
16	8	136	30	
16	9	–	27	
16	10	137	24	
16	11	138	21	
16	12	139	18	
16	13	–	15	
16	14	140	12	
16	15	142	9	
16	16	–	6	
16	17	143	3	
16	18	–	0	

XC95288 Global, JTAG and Power Pins

Pin Type	HQ208
I/O/GCK1	44
I/O/GCK2	46
I/O/GCK3	55
I/O/GTS1	7
I/O/GTS2	9
I/O/GTS3	3
I/O/GTS4	5
I/O/GSR	206
TCK	98
TDI	94
TDO	176
TMS	96
V _{CCINT} 5 V	11,59,124,153,204
V _{CCIO} 3.3 V/5 V	1,26,53,65,79,92,105, 132,157,172,181,184
GND	2,13,24,27,42,52,68,81, 93,104,108,129,130, 141,156,163,177, 190,207
No Connects	-